

A Need for New Techniques

In the 1980s, floods inflicted around \$1.5 billion of damage annually in the U.S. Over the past 5 years, that figure has more than quintupled to around \$8 billion. And yet, tools used to assess flooding risk have not kept pace. Flood maps, the primary means for estimating flood risk, remain time-consuming and computationally intensive, leaving communities unable to predict and prepare for floods.

To enhance the flood resilience of cities, CSHub researchers have begun to develop a new flooding model based on their prior city texture research. The model aims to describe the risk of urban precipitation flooding as well as assess potential flooding damage to buildings and infrastructure.

Learning from Materials Science

Researchers use a statistical physics-based model called density functional theory (DFT) to evaluate the flooding risk of precipitation flooding. This model was originally

Key Takeaways:

- Though flooding damage has grown dramatically, cities lack the tools to adequately predict and mitigate it.
- To enhance the flood resilience of cities, CSHub has developed a model that simulates flooding in 3D city configurations. The model relies on density functional theory—a technique of materials science—to model urban flooding based on the absorption and adsorption processes of porous materials.
- The proposed approach would make it possible to account for city texture in the risk evaluation for the damage of buildings and infrastructure.
- Due to its computational simplicity, the DFT model could also offer faster and more detailed analyses of flood risks.

Figure 1. A city/neighborhood model (36m x 36m x 36m) which consists of 1. four buildings (10m x 10m x 10m), 2. two-lane road (2x3.6m), 3. green areas.

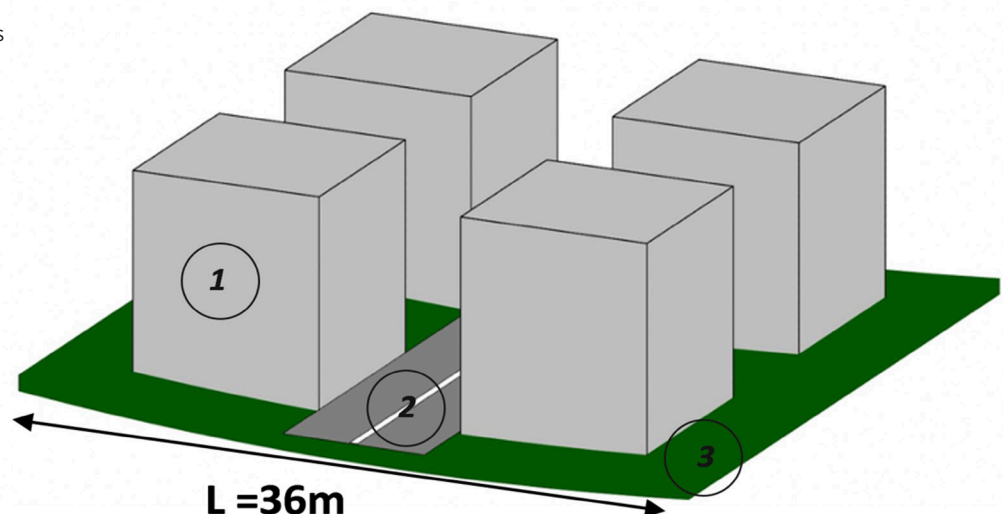

developed in material science for adsorption and desorption processes for porous materials to identify the porous space. The DFT model is an equilibrium-based approach that includes a probabilistic analysis to find the density distribution of a fluid on surfaces and in pore space. In their approach, researchers apply this DFT model to cities by analogy.

Efficient Flood Modeling

Researchers applied this DFT model to a three-dimensional configuration of a neighborhood. For these simulations, they defined different city elements, such as buildings, streets, and green areas (see **Figure 1**), which occur at specified densities in the system. The adsorption and desorption isotherms, which we call flooding and drainage isotherms, are the output of the DFT model for the city configuration shown in **Figure 1**.

They identify, within a grand canonical ensemble, the likelihood of finding fluid particles at the different locations of a city based on the city's topography from an adsorption-desorption perspective. As this model is less computationally intensive than conventional counterparts, it has the potential to produce more detailed results, more quickly.

The adsorption and desorption isotherms for this configuration are shown in **Figure 2** where the normalized height of the water after equilibrium has been reached is plotted versus the normalized precipitation rates. These curves capture the different flooding and drainage states for each precipitation rate. The hysteresis loop of the system, the difference between the flooding and drainage isotherms, indicates the irreversibility of the flooding-drainage procedure.

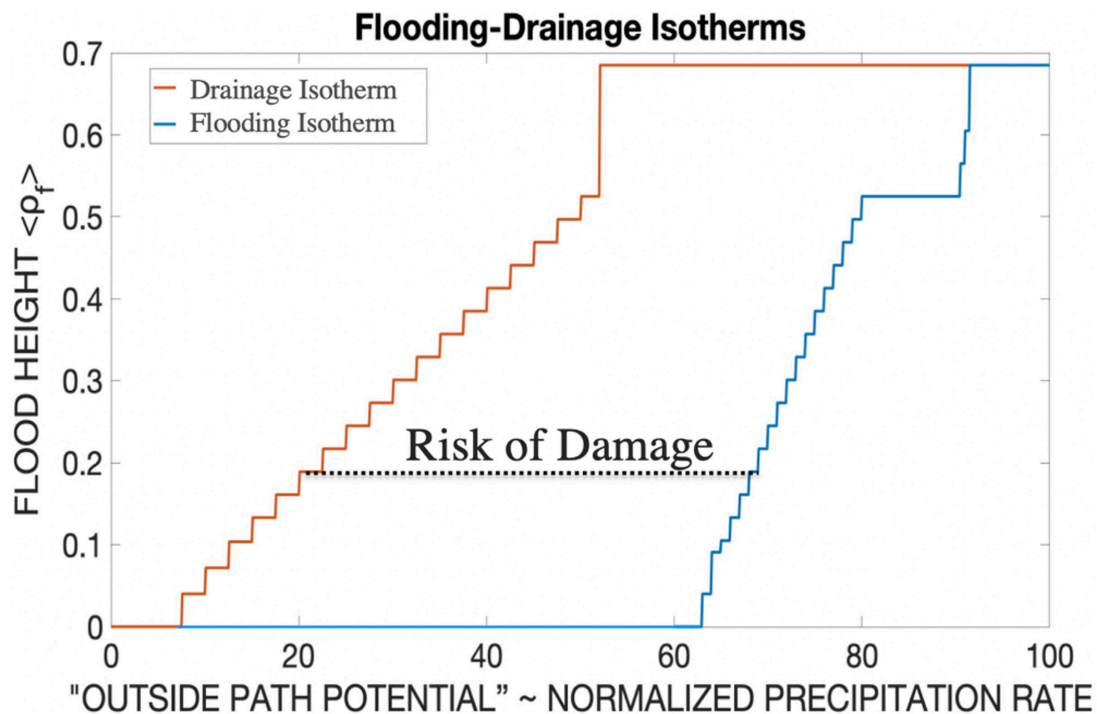

Figure 2. Flooding-drainage isotherms for 3D city/neighborhood configuration

This delayed draining is considered as a means of measuring the risk of long flooding exposure.

In the next steps, this hysteresis loop will be used as a means of assessing the risk of damage done to the infrastructure of cities as well as for evaluating the impact of city texture on flooding risk. As they hone their model, researchers also plan to compare its efficacy with other conventional approaches.

Related Links:

- [CSHub City Texture Research](#)
- [CSHub Buildings Research](#)
- [CSHub Buildings Resilience Research](#)

Citation:

Vartziotis, E. (2021). "Precipitation Flooding in Urban Environments." CSHub Research Brief. Volume 2021, Issue 1.

This research was carried out by CSHub with sponsorship provided by the Portland Cement Association and the Ready Mixed Concrete Research & Education Foundation. CSHub is solely responsible for content.